















I SUPPORTI

BRACKET INFORMATION

I supporti F.I.R. sono prodotti secondo le normative ISO 2184, riguardanti le dimensioni e i fori delle piastre. La nostra gamma di supporti include anche piastre e forcelle con le dimensioni richieste dal mercato nord americano.

F.I.R. brackets are manufactured according to ISO 2184 standards with respect to the top plate and hole dimensions. In response to customer demand, F.I.R. also manufactures a range of plates and forks according to Northern American specifications.

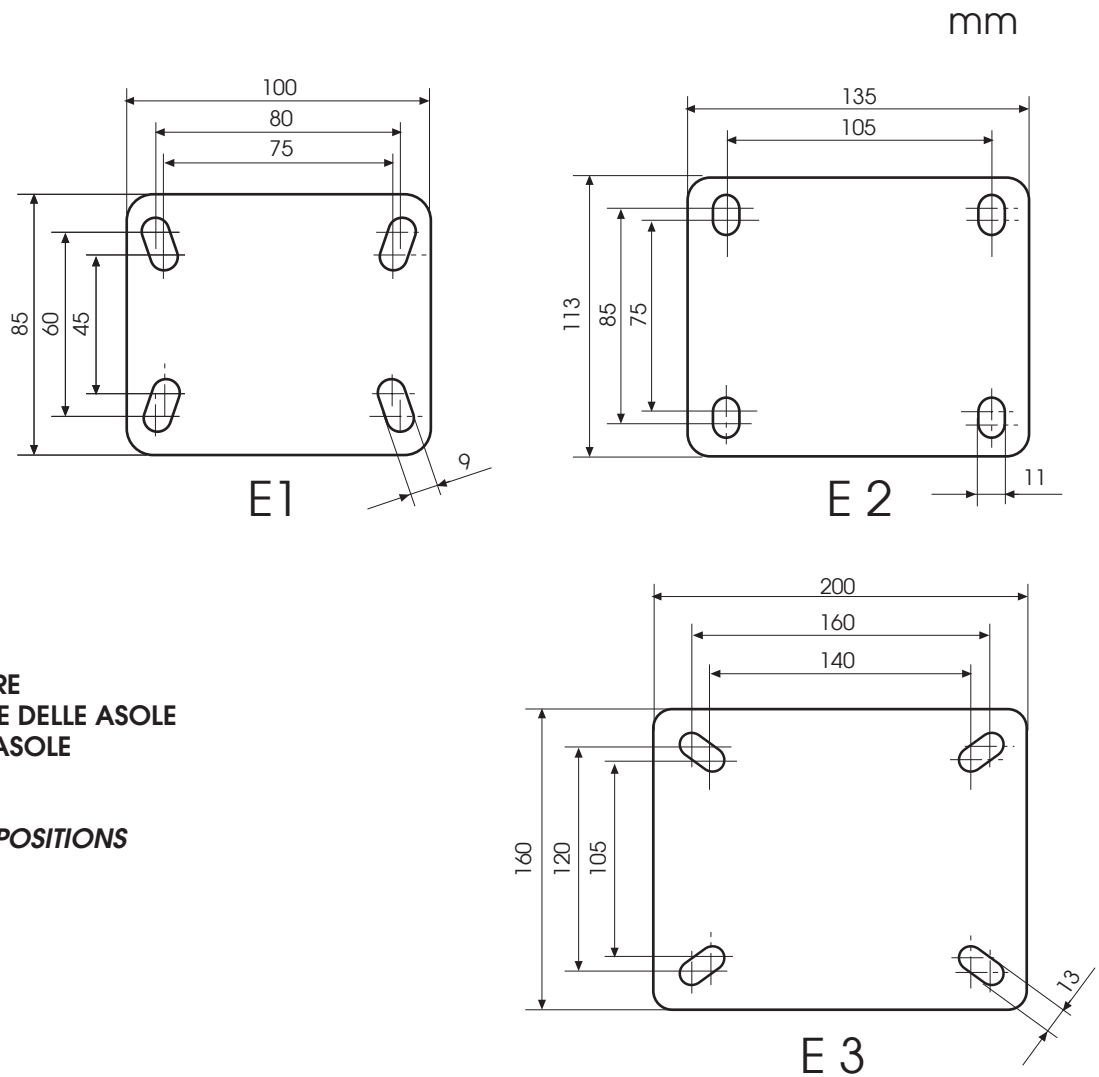

**DIMENSIONI DELLE PIASTRE**  
**POSIZIONE E DIMENSIONE DELLE ASOLE**  
**DIMENSIONE INTERASSE ASOLE**

**TOP PLATE DIMENSIONS**  
**HOLE DIMENSIONS AND POSITIONS**  
**PLATE HOLE DISTANCE**

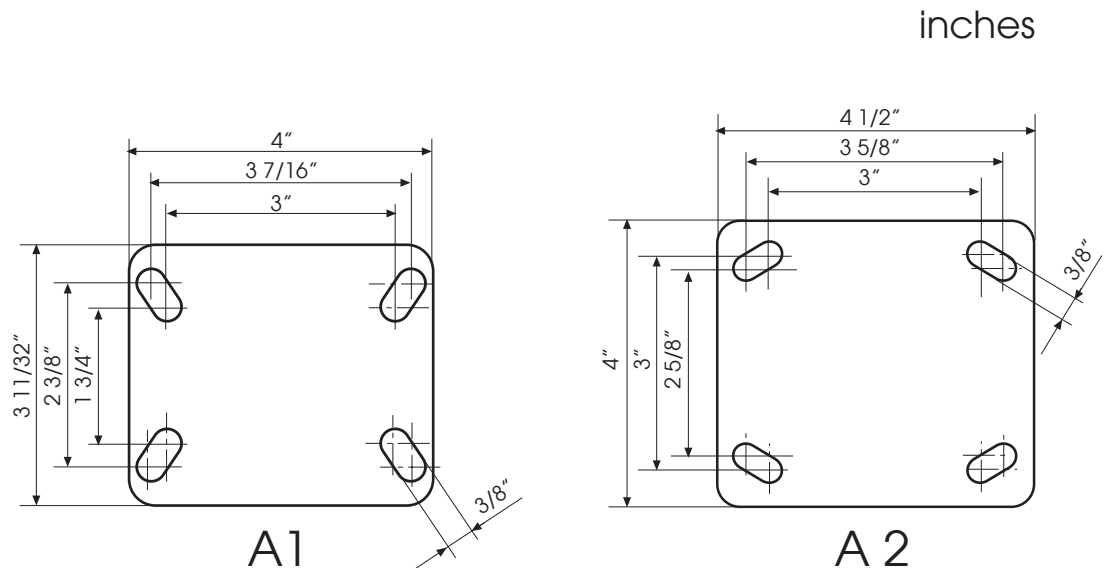
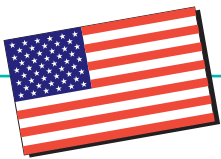

inches



## MONTAGGIO DEI SUPPORTI AL CARRELLO

F.I.R. assicura l'ottimale funzionamento e una lunga durata di ruota e supporto, qualora siano rispettate le seguenti condizioni:

- la ruota deve essere applicata ad un supporto adatto, utilizzando accessori originali e di dimensioni adeguate.
- verifica della libera rotazione dopo aver fissato la ruota.
- i supporti a piastra devono essere fissati utilizzando viti, dadi e rondelle del tipo, dimensione e quantità indicati dal costruttore.
- i supporti a codolo devono essere applicati in strutture tubolari aventi una tolleranza molto stretta.
- i supporti a foro passante devono essere fissati mediante una vite di dimensione e tipo indicati dal costruttore
- la base superiore dei supporti deve aderire perfettamente e per intero al piano di montaggio.

## FITTING BRACKET TO EQUIPMENT

*We guarantee the performance and the life of our wheels and casters, in line with the product warranty, providing the following conditions are fulfilled:*

- *the wheel must be fitted into the correct fork using the original axles, bolts and nuts of the correct dimensions*
- *verification of free rotation of the wheel after fitting*
- *the top plate caster must be fitted with bolts, nuts and washers of the correct size and quantities indicated by the manufacturer.*
- *solid stem casters must be fitted into tubular structures with tight tolerance.*
- *mounting plane surface of bolt hole or threaded casters must adhere perfectly to the mounting plane of the equipment.*
- *bolt hole casters must be fitted using a bolt as recommended by the manufacturer*

## STANDARD

Le ruote ed i supporti F.I.R. sono prodotti in accordo con le seguenti normative:

- ISO 22877 - UNI EN 12526
- ISO 22878 - UNI EN 12527
- ISO 22881 - UNI EN 12530
- ISO 22883 - UNI EN 12532
- ISO 22884 - UNI EN 12533

## ADDITIONAL STANDARDS

*F.I.R. wheels and brackets are manufactured according to the following ISO:*

- ISO 22877 - UNI EN 12526
- ISO 22878 - UNI EN 12527
- ISO 22881 - UNI EN 12530
- ISO 22883 - UNI EN 12532
- ISO 22884 - UNI EN 12533



I prodotti F.I.R. sono prodotti in ottemperanza alla Direttiva Europea 2000/53/CE relativa ai veicoli fuori uso ed alla Direttiva Europea EU 2002/95/CE (RoHS) "Restrizione dell'uso di sostanze pericolose in apparecchiature elettriche ed elettroniche" e alla direttiva REACH (EC) 1907/2006 e successive estensioni, incluso SVHC 2022.



*F.I.R. products are manufactured in compliance with European Directive 2000/53/CE on end-of-life vehicles and European Directive EU 2002/95/CE (RoHS) "Restriction of the use of certain hazardous substances in electrical and electronic equipment" and with regulation REACH (EC) 1907/2006 and following extensions, including SVHC 2022.*



### FIR per l'ambiente

**FIR coniuga qualità, innovazione e rispetto per l'ambiente.**

**A questo proposito, abbiamo identificato i prodotti che possono essere riciclati o rigenerati e ne incoraggiamo l'utilizzo.**

### *FIR for the environment*

***FIR combines quality, innovation and respect for the environment.***

***To this end, we have identified those products that may be recycled or regenerated. We strongly encourage use of these products.***

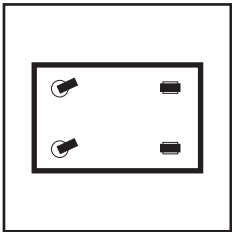

### 2 SUPPORTI GIREVOLI + 2 SUPPORTI FISSI

Questa soluzione offre una buona capacità di carico e manovrabilità. E' una soluzione sicura contro eventuali pericoli di ribaltamento. È l'applicazione più praticata su carrelli per uso industriale. Consigliamo la spinta o trascinamento dal lato delle due ruote girevoli. La capacità max di portata è data da  $\text{da} = \frac{\text{peso totale}}{3}$

### 2 SWIVEL BRACKETS AND 2 FIXED BRACKETS

This solution provides a good load capacity and manoeuvrability; accurate steering is guaranteed. This is the most practical solution for use in industrial trolleys. We suggest that the equipment be pushed from the side of the 2 swivel wheels. Maximum load on each wheel is given by  $= \frac{\text{total weight}}{3}$

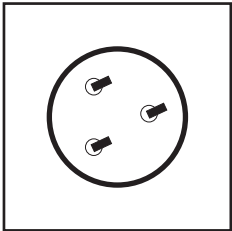

### 3 SUPPORTI GIREVOLI

Questa soluzione offre una buona capacità di carico ed un'ottima manovrabilità in spazi limitati. I carrelli con questa configurazione sono difficili da guidare, specialmente su superfici sconnesse, e non assicurano una buona stabilità a pieno carico.

### 3 SWIVEL BRACKETS

This solution provides good load capacity combined with optimal manoeuvrability. Equipment fitted in this way may be difficult to steer, specially on uneven floors. Stability cannot be guaranteed when carrying a high load.

La capacità max di portata è data da  $\text{da} = \frac{\text{peso totale}}{2,5}$

Maximum load on each wheel is given by  $= \frac{\text{total weight}}{2,5}$

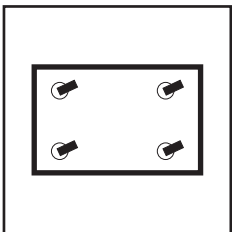

### 4 SUPPORTI GIREVOLI

Questa soluzione offre una buona capacità di carico ed un'ottima manovrabilità in spazi limitati. Non è consigliata per percorsi lineari e su piani inclinati. Il corretto stazionamento del carrello non è assicurato anche se due supporti sono dotati di dispositivo frenante. La capacità max di portata è data da  $\text{da} = \frac{\text{peso totale}}{3}$

### 4 SWIVEL BRACKETS

This solution provides good load capacity combined with optimal manoeuvrability. It is not recommended for applications where use on straight runs or ramps is required. The correct functioning of the device cannot be guaranteed if two brackets are fitted with a front brake.. Maximum load on each wheel is given by  $= \frac{\text{total weight}}{3}$

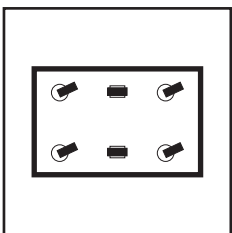

### 4 SUPPORTI GIREVOLI + 2 SUPPORTI FISSI CENTRALI

Questa soluzione offre un'elevata capacità di carico ed un'eccellente manovrabilità. E' raccomandata per carrelli di grandi dimensioni ed alte portate. Consente di effettuare la spinta da entrambi i lati con supporti girevoli. La capacità max di portata è data da  $\text{da} = \frac{\text{peso totale}}{4}$

### 4 SWIVEL BRACKETS AND 2 FIXED BRACKETS CENTRALLY PIVOTING

This solution provides high load capacity and excellent manoeuvrability. This is the recommended solution for long trolleys carrying heavy loads. The two central fixed brackets require 25 mm packing to allow alternate support by the swivel brackets. Maximum load on each wheel is given by  $= \frac{\text{total weight}}{4}$

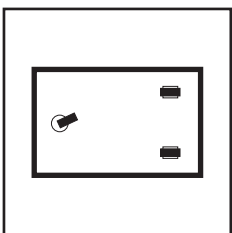

### 1 SUPPORTO GIREVOLE + 2 SUPPORTI FISSI

Questa soluzione economica offre una portata limitata e una buona manovrabilità. I carrelli con questa configurazione sono poco stabili, specialmente a piena portata e il carico deve essere equamente distribuito.

### 1 SWIVEL CASTER AND 2 FIXED BRACKETS

This solution provides low load capacity and good manoeuvrability. Equipment fitted in this way may be unstable when loaded. The load should be evenly distributed.

La capacità max di portata è data da  $\text{da} = \frac{\text{peso totale}}{2,5}$

Maximum load on each wheel is given by  $= \frac{\text{total weight}}{2,5}$

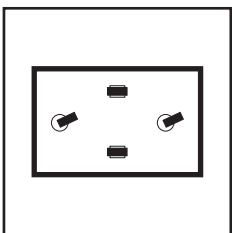

### 2 SUPPORTI GIREVOLI + 2 SUPP. FISSI CENTRALI

Questa soluzione offre una buona capacità di carico ed un'eccellente manovrabilità. E' raccomandata per carrelli utilizzati in condizioni di spazio limitato. Il carico maggiore viene sopportato dalle due ruote fisse centrali, mentre le girevoli si appoggiano alternativamente con sbalzo di almeno 15 mm. La capacità max di portata è data da  $\text{da} = \frac{\text{peso totale}}{2}$

### 2 SWIVEL BRACKETS AND 2 FIXED BRACKETS CENTRALLY PIVOTING

This solution provides good load capacity and excellent manoeuvrability. This is the recommended solution for equipment working in limited space. The two central fixed brackets require 25 mm packing to allow alternate support by the swivel brackets. Maximum load on each wheel is given by  $= \frac{\text{total weight}}{2}$



PORTATA IN FUNZIONE  
DELLA TEMPERATURALOAD CAPACITY  
AS A FUNCTION OF  
TEMPERATURE

TEMPERATURA °C • TEMPERATURE °C								
	-40/-20	-20/0	0/+20	+20/+40	+40/+60	+60/+80	+80/+120	>+120
% PORTATA • % LOAD CAPACITY								
<b>NYLGOM</b>	40	100	100	100	95	50	-	-
<b>BLUE NYLGOM</b>	40	100	100	100	95	50	-	-
<b>PHENOLIC</b>	50	100	100	100	100	100	100	100
<b>HT-RUBBER</b>	40	100	100	100	100	100	100	100
<b>NYLON HT</b>	-	100	100	100	100	100	90	-
<b>NYLON</b>	50	100	100	100	90	70	60	-
<b>NYLON COMPACT</b>	50	100	100	100	90	70	60	-
<b>SUPERLAN</b>	-	100	100	100	90	70	40	-
<b>SUPERLAN COMPACT</b>	-	100	100	100	90	70	40	-
<b>SUPERLAST</b>	-	100	100	100	85	60	-	-
<b>POLIFLEX</b>	-	50	100	100	85	40	-	-
<b>ALTEC</b>	-	100	100	100	90	70	40	-
<b>ALGOM</b>	40	100	100	100	95	50	-	-
<b>GHIPOL</b>	-	100	100	100	90	80	40	-
<b>GHISA</b>	100	100	100	100	100	100	100	100
<b>GHITEC</b>	-	100	100	100	90	80	40	-
<b>NYL ROLLER</b>	50	100	100	100	90	70	60	-
<b>NYLPOL ROLLER</b>	-	100	100	100	90	80	40	-
<b>ACCTEC ROLLER</b>	-	100	100	100	90	80	40	-
<b>M-ROLL</b>	50	100	100	100	90	70	60	-

Le caratteristiche, le illustrazioni e le descrizioni sono indicative e possono subire modifiche senza preavviso.

I prodotti illustrati non implicano necessariamente la loro disponibilità a magazzino.

Le prove effettuate sono riferite a prodotti originali e con accessori originali.

La sostituzione di qualsiasi componente non di produzione F.I.R. potrebbe modificare le prestazioni e invalidare così ogni garanzia.

















La F.I.R. non si assume nessuna responsabilità per eventuali danni causati da un uso improprio o dall'uso di accessori non originali.

Le illustrazioni riportate in questo catalogo sono riferite alla produzione standard al momento della redazione e stampa.

*Specifications, illustrations, dimensions and descriptions are indicative and subject to variation without prior notice. Products as illustrated herein do not necessarily imply their availability in stock as illustrated. Tests undertaken refer to original products fitted with original accessories. Replacement of any component with one from another manufacturer might modify the results and will invalidate any guarantee. F.I.R. will not assume any responsibility for damage caused by improper use or by replacement fittings other than those supplied by F.I.R. S.r.l.*







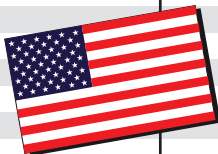









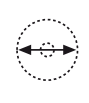













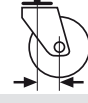
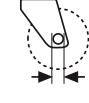

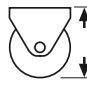
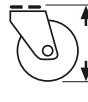
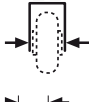





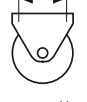



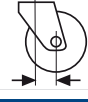
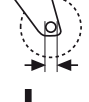





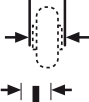



*Illustrations shown in this catalogue refer to our standard production range at the time of printing.*

TAVOLE DI CONVERSIONE • CONVERSION TABLES

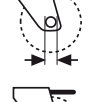
RUOTA WHEEL				SUPPORTO BRACKET		PORTATA LOAD CAPACITY	
							
mm inches		mm inches		mm inches		mm inches	kg. lbs
40 1-9/16"		8 0-5/16"		55 2-5/32"		6 0-15/64"	30 66
50 1-31/32"		12 0-15/32"		60 2-23/64"		6,5 0-1/4"	40 88
60 2-23/64"		15 0-19/32"		62 2-7/16"		8 0-1/4"	50 110
70 2-7/8"		20 0-25/32"		68 2-11/16"		9 0-11/32"	60 132
80 3-5/32"		25 0-63/64"		75 2-15/16"		11 0-7/16"	75 165
82 3-7/32"				80 3-5/32"		12 0-15/32"	80 176
85 3-11/32"				88 3-15/32"		13 0-3/64"	100 220
100 3-15/16"				90 3-17/32"		14 0-9/16"	110 242
125 4-59/64"				91 3-19/32"		16 0-5/8"	120 264
150 5-22/32"		mm inches		93 3-21/32"			130 286
175 6-7/8"		22 0-7/8"		100 3-15/16"			140 308
200 7-7/8"		28 1-3/32"		108 4-1/4"			150 330
225 8-55/64"		40 1-37/64"		110 4-13/32"			160 352
250 9-27/32"		45 1-25/32"		113 4-29/64"		mm inches	170 374
300 11-13/16"		50 1-31/32"		125 4-59/64"		17 0-21/32"	180 396
		55 2-5/32"		127 5		22 0-7/8"	200 440
		56 2-3/16"		128 5-3/64"		27 1-1/16"	220 485
mm inches		58 2-9/32"		129 5-5/64"		38 1-1/2"	260 573
18 0-23/32"		66 2-19/32"		130 5-4/32"		40 1-9/16"	270 595
22 0-7/8"		70 2-7/8"		132 5-3/16"		42 1-21/32"	280 617
24 0-15/16"				133 5-1/4"		44 1-47/64"	290 639
25 0-63/64"				134 5-9/32"		46 1-13/16"	300 661
28 1-3/32"		mm inches		148 5-27/32"		50 1-31/32"	320 705
30 1-3/16"		32 1-1/4"		155 6-7/64"		52 2-3/64"	330 727
32 1-1/4"		35 1-3/8"		156 6-1/8"		54 2-1/8"	400 881
33 1-5/16"		40 1-9/16"		158 6-7/32"		56 2-3/16"	450 991
35 1-3/8"		42 1-21/32"		159 6-1/4"		65 2-9/16"	480 1057
36 1-7/16"		44 1-21/32"		160 6-5/16"		66 2-19/32"	500 1101
37,5 1-15/32"		47 1-27/32"		164 6-7/16"		74 2-29/32"	600 1322
38 1-1/2"		52 2-3/64"		165 6-1/2"			620 1366
40 1-37/64"				170 6-11/16"			650 1432
45 1-25/32"				181 7-1/8"			700 1543
48 1-7/9"				183 7-13/64"		mm inches	800 1762
50 1-31/32"		mm inches		184 7-1/4"		10 0-3/8"	900 1982
55 2-5/32"		32 1-1/4"		187 7-23/64"		12 0-15/32"	1000 2203
70 2-7/8"		35 1-3/8"		188 7-13/32"		16 0-5/8"	1050 2313
80 3-5/32"		40 1-9/16"		193 7-19/32"		20 0-25/32"	1100 2423
82 3-7/32"		42 1-21/32"		195 7-11/16"		22 0-7/8"	1150 2533
90 3-17/32"		44 1-21/32"		202 7-61/64"		26 1-1/64"	1200 2643
100 3-15/16"		47 1-27/32"		205 8-5/64"		29 1-1/8"	1400 3086
		52 2-3/64"		208 8-3/16"			1500 3306
				210 8-9/32"			1700 3744
				212 8-23/64"			1800 3965
				219 8-5/8"			
				222 8-3/4"			
				233 9-11/64"		mm inches	
				237 9-21/64"		25 0-63/64"	
				243 9-9/16"		50 1-31/32"	
				244 9-39/64"		58 2-9/32"	
				245 9-21/32"		60 2-23/64"	
				288 11-11/32"			
				293 11-17/32"			
				310 12-3/16"			
						mm inches	
				42x42 1-21/32"x1-21/32"		32 1-1/4"	
				60x60 2-23/64"x2-23/64"		40 1-9/16"	
				100x85 3-5/16"x3-11/32"		42 1-21/32"	
				135x110 5-10/32"x4-13/32"		78 3-5/64"	
				140x110 5-33/64"x4-13/32"		103 4-1/16"	
				200x160 7-7/8"x6-5/16"			
						mm inches	
				30x30 1-3/16"x1-3/16"		10 0-3/8"	
				45x45 1-25/32"x1-25/32"		12 0-15/32"	
				80x60 3-5/12"x2-23/64"		16 0-5/8"	
				105x80 4-1/8"x3-5/32"			
				160x120 6-5/16"x4-23/32"			





SUPPORTO BRACKET		RUOTA WHEEL		RUOTA CON SUPPORTO CASTER			
	Supporto girevole a piastra Top plate swivel bracket		Diametro ruota Wheel diameter	<b>SUPPORTO GIREVOLE A PIASTRA TOP PLATE SWIVEL BRACKET</b>		<b>SUPPORTO GIREVOLE A CODOLO STEM SWIVEL BRACKET</b>	
	Supporto fisso Fixed bracket		Larghezza fascia Tread width		Altezza totale Total height		Altezza totale Total height
	Diametro ruota consigliata Recommended wheel diameter		Diametro foro Wheel hole diameter		Dimensioni piastra Plate dimensions		Diametro codolo Stem diameter
	Apertura forcella Fork width		Lunghezza mozzo Hub length		Interasse asole Plate hole distance		Altezza codolo Stem height
	Dimensioni piastra Plate dimensions		Diametro sede cuscinetti Bearing seat diameter		Dimensione asole Plate hole diameter		Diametro piastra Round plate diameter
	Interasse asole Plate hole distance		Profondità sede cuscinetti Bearing seat depth		Disassamento Offset		Disassamento Offset
	Foro per assale Axle hole diameter	<b>MOZZO HUB</b>		<b>SUPPORTO FISSO FIXED BRACKET</b>		<b>SUPPORTO GIREVOLE A FORO PASSANTE BOLT HOLE SWIVEL BRACKET</b>	
	Supp. girevole a foro passante Bolt hole swivel bracket		Foro passante Plain bore		Altezza totale Total height		Altezza totale Total height
	Apertura forcella Fork width		Boccole teflon Teflon bush		Dimensioni piastra Plate dimensions		Diametro foro Bolt hole diameter
	Diametro piastra Round plate diameter		Boccola con bussola With bushes		Interasse asole Plate hole distance		Diametro piastra Round plate diameter
	Diametro foro passante Bolt hole diameter		Rulli ferro Roller bearing		Dimensione asole Plate hole diameter		Disassamento Offset
	Foro per assale Axle hole diameter		Rulli inox Inox roller bearing	<b>ACCESSORI ACCESSORIES</b>			
	Supp. girevole a codolo Stem swivel bracket		Sede cuscinetto Ball bearing seat		Pararifi Threadguards		Vite Stem screw
	Apertura forcella Fork width		Cuscinetto Ball bearing	<b>PORTATA LOAD CAPACITY</b>			
	Diametro piastra Round plate diameter	<b>PNEUMATICA PNEUS</b>			Portata Load capacity	<b>FRENO BRAKE</b>	
	Diametro codolo Stem diameter		Battistrada Profile		Portata con cuscinetto Load capacity with ball bearing		Freno posteriore Rear total brake
	Foro per assale Axle hole diameter		Pressione atm Pressure	<b>FRENO ANTERIORE FRONT TOTAL BRAKE</b>			
	Freno anteriore Front total brake					Freno anteriore Front total brake	
	Freno posteriore Rear total brake					Freno anteriore Front total brake	